

David Clark COMPANY INCORPORATED

360 Franklin Street, Box 15054, Worcester, MA 01615-0054
TEL.: (508) 751-5800 E-Mail: sales@DavidClark.com FAX: (508) 753-5827

PARTS LIST MODEL H10-00

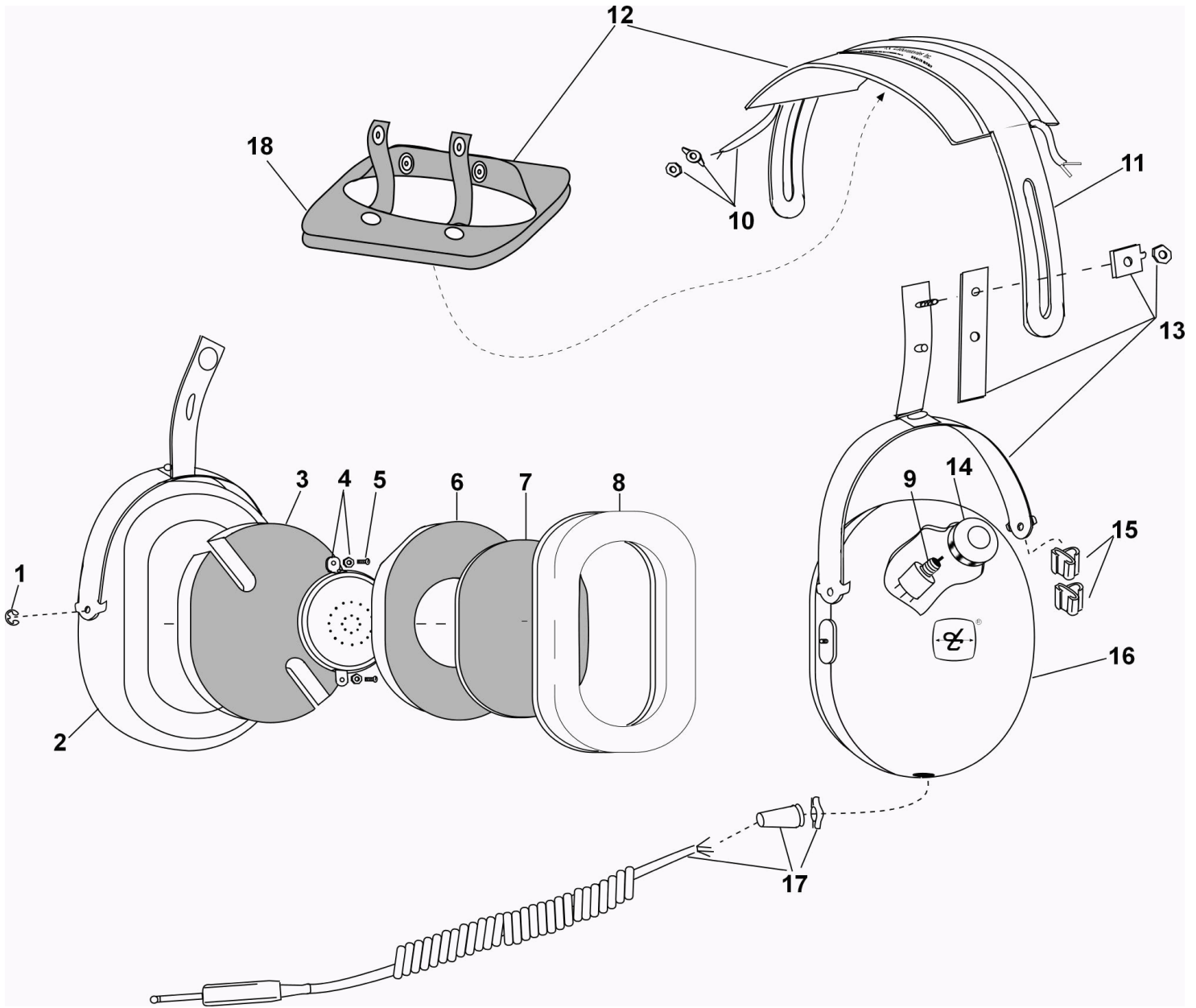

No.	Description	Part No.
1	Retaining Ring (10/pk)	00009M-03
2	Dome, Right	11696P-12
3	Dome Filter	26475P-02
4	Earphone Assembly	10376G-20
5	Screw (10/pk)	13180P-06
6	Dome Filter	25629P-03
7	Filter	14096P-09
8	Undercut Gel Earseal (pair)	40863G-02
9	Volume Control	09349P-34

No.	Description	Part No.
10	Overhead Cord Assy Kit	22607G-01
11	Headband Spring	15093P-01
12	Headpad Assembly	18900G-45
13	Stirrup & Clamp Kit	22378G-08
14	Volume Control Knob	15109P-01
15	Clip, Cord (4/pk)	15125P-02
16	Left Dome	11696P-13
17	Comm Cord Kit	18028G-02
18	Headpad Restraint, Foam	40266G-01

ELECTRICAL SCHEMATIC
MODEL H10-00

